

# THYROID HORMONE CELL- -MEMBRANE TRANSPORTERS DEFECT

• *a novel genetic syndrome of thyroid hormone resistance* •

---

Mateus Fernandes da Silva Medeiros<sup>a</sup>  
Helton Estrela Ramos<sup>b</sup>

## Abstract

Many studies has confirmed the crucial role of thyroid hormone transporters for TH action in human target cells. The importance was better understood by observing the phenotype in patients harboring mutations of the monocarboxylate transporter 8 (MCT8) gene immediately linked to Allan-Herndon-Dudley Syndrome (AHDS), in which severe neurological findings are associated with abnormal Thyroid hormone levels. The disease is X-chromossome linked, with males presenting a homogeneous neurological psychomotor phenotype and mental retardation associated with low serum  $T_4$  and elevated  $T_3$  levels. The mechanism of disease is still obscure and either the physiopathology as the existent therapeutic options need to be better studied.

*Keywords:* MCT8. Allan-Herndon-Dudley Syndrome.

## INTRODUCTION

Correct intracellular  $T_3$  concentration is important for the normal human development and exerts its action on virtually all type of tissues. It has been thought initially that thyroid hormone (TH) entrance into the target cells occurred by passive diffusion through the lipid cell membranes. But it has been found many transporters that

selectively facilitates the TH passage across the cell membrane.<sup>(1)</sup> The important role of transporters for TH in humans was established by the observations in patients harboring mutations of *the monocarboxylate transporter 8 (MCT8)* gene which presented severe neurological findings associated with unusual abnormalities in thyroid function.<sup>(2, 3)</sup>

---

Corresponding author: ramoshelton@gmail.com

a. Medical Student, Federal University of Bahia

b. MD, PhD, Adjunct Professor, Department of Biorregulation, Health & Science Institute, Federal University of Bahia, Salvador, Brazil;

MCT8 is expressed in many tissues throughout the body, including the brain, skeletal muscle, liver and placenta.<sup>(1)</sup> This contribution illustrates how a genetic disease perturbing the supply of biological active TH to cells affects the development and maturation of the central nervous system.

## PATHOPHYSIOLOGY OF THYROID HORMONE CELL-MEMBRANE TRANSPORT DEFECTS

The syndrome has been identified in more than 200 affected males belonging to some 100 families, and only one sporadic case of a female carrying a disrupted MCT8 gene in combination with unfavorable nonrandom X-inactivation.<sup>(4-6)</sup> These mutations (OMIM#300523) include large deletions, insertions, nonsense mutations and missense mutations.<sup>(4, 5)</sup> Some variation of the severity of the can be explained by mutations that cause reduced, but not absent, TH transport.<sup>(4, 5, 7)</sup>

In MCT8 deficient patients, the decreased  $T_3$  supply to neuronally expressed  $D_3$  will result in a decreased  $T_3$  clearance. This gives rise to increased serum  $T_3$ , which will stimulate renal and hepatic  $D_1$  activity and, thus, increase  $T_3$  production. This increased  $D_1$  activity contributes, in part, to the lower  $T_4$  and

$rT_3$  serum levels.<sup>(8, 9)</sup> The elevated TSH levels despite the high serum  $T_3$  reflects pituitary resistance to  $T_3$ . In contrast, there is evidence for a thyrotoxic state of the liver and skeletal muscle in MCT8 patients, suggesting that TH is taken up by the cells predominantly via other transporters than MCT8.<sup>(1)</sup> The  $T_3$  entry in some important tissues such as bone, skeletal muscle, heart, liver and intestine might be raised in the presence of high serum levels of  $T_3$ , then it might be observed advanced bone age, muscle wasting, malnutrition and elevation of markers of thyroid hormone action in each organ of MCT8 patients.<sup>(5, 10)</sup>

## PHENOTYPE OF THYROID HORMONE CELL-MEMBRANE TRANSPORT DEFECTS

The hereditary pattern of MCT8 defect transmission is Mendelian X-chromosome linked, with males presenting a typical neurological psychomotor phenotype, low serum  $T_4$  and reverse  $T_3$  but elevated  $T_3$  and normal or slightly elevated TSH. The main findings in MCT8 patients described in the literature are summarized in Table 1<sup>(4, 5, 10-14)</sup> and consists in the coexistence of hyperthyroid and hypothyroid tissues. **The structure of the MCT8 gene is showed in Figure 1.**

**Table 1.** Phenotype of MCT8 gene mutated patients.

<p><b>Neurologic symptoms and signs</b>                  Motor delay, Inability to walk or Ataxia, Choreoathetoid movements, Spastic quadriplegia                  Mental Retardation, IQ reduction, Truncal hypotonia,</p>
<p><b>Thyroid Gland</b>                  Reduced or Normal FT4                  High serum FT3                  Low rT3</p>

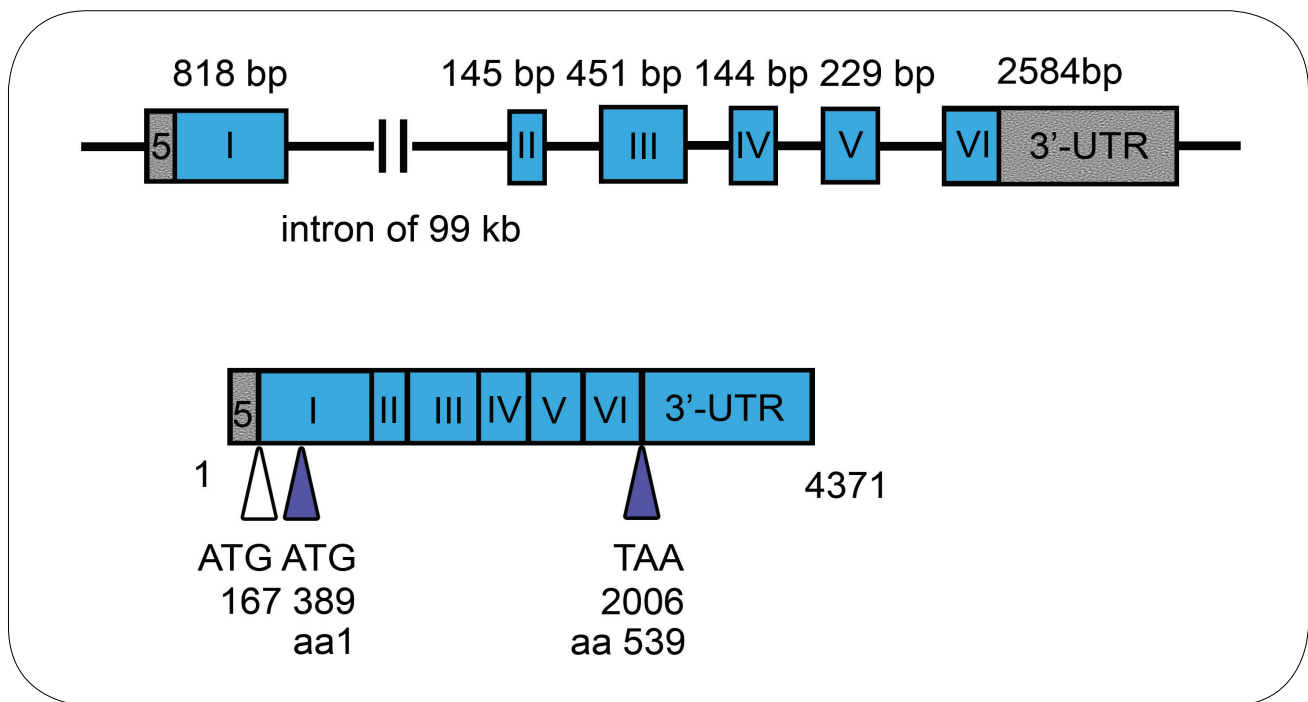

**Figure 1.** The structure of the MCT8 gene

Roman numbers represent exons. Both ATG codons represent the putative translation start sites. TAA is the stop codon.

## MANAGEMENT OF MONOCARBOXYLATE TRANSPORTER 8 DEFICIENT PATIENTS

Currently, the management of the disorder is limited to few options and none efficient in correcting the defect. They do not benefit from substitution therapy with L-T<sub>3</sub> and/or L-T<sub>4</sub>, with no changes in the mental and neurological development and administration of supraphysiological doses of TH could provoke impairment of the hypermetabolic state and selective tissue thyrotoxicity.<sup>(1, 5)</sup> The use of 3,5-diiodothyropropionic acid (DITPA) has been proposed as feasible TH analogue which does not require MCT8 for T<sub>3</sub> transport but binds to TH receptor  $\alpha$  and  $\beta$ .<sup>(15)</sup> To date, the promising thymimetic effects of high doses of DITPA (1-2 mg/kg · d) in the MCT8 patients tested normalizes the T<sub>3</sub> and TSH levels, associated with T<sub>4</sub> and rT<sub>3</sub> elevation to the lower normal range.

## CONCLUSIONS

MCT8 gene mutations produce X-linked mental retardation, congenital hypotonia and spastic quadriplegia in association with typical thyroid test abnormalities. The irreversible severe psychomotor phenotype observed in these patients clearly attests the vital role of TH in human neuronal development. The thyroidal phenotype includes high serum levels of serum T<sub>3</sub>, low levels of reverse T<sub>3</sub> and T<sub>4</sub> and high/normal levels of TSH.

## ACKNOWLEDGMENTS

Disclosure Summary: The author have nothing to disclosure.

Some of data presented were collected using funding provided, in part, by a grant from FAPESB (RED0014/2012; PET0002/2013; RED0010/2013 and APP0040/2011) and CNPq (Edital Universal N° 14/2012; Processo n°.470354/2012-7). Thanks to Lucio Souza Almeida (IRMA ART) for figure construction.

## References

1. Visser WE, Friesema EC, Visser TJ. Minireview: thyroid hormone transporters: the knowns and the unknowns. *Mol Endocrinol.* 2011;25:1-14.
2. Dumitrescu AM, Liao XH, Best TB, Brockmann K, Refetoff S. A novel syndrome combining thyroid and neurological abnormalities is associated with mutations in a monocarboxylate transporter gene. *Am J Hum Genet.* 2004; 74:168-175.
3. Friesema EC, Grueters A, Biebermann H, Krude H, von Moers A, Reeser M et al. Association between mutations in a thyroid hormone transporter and severe X-linked psychomotor retardation. *Lancet.* 2004; 364:1435-1437.
4. Friesema EC, Visser WE, Visser TJ. Genetics and phenomics of thyroid hormone transport by MCT8. *Mol Cell Endocrinol.* 2010; 322:107-113.
5. Fu J, Refetoff S, Dumitrescu AM. Inherited defects of thyroid hormone-cell-membrane transport: review of recent findings. *Curr Opin Endocrinol Diabetes Obes.* 2013; 20:434-440.
6. Frints SG, Lenzner S, Bauters M, Jensen LR, Van Esch H, des Portes V et al. MCT8 mutation analysis and identification of the first female with Allan-Herndon-Dudley syndrome due to loss of MCT8 expression. *Eur. j. hum. genet.* 2008; 16:1029-1037.
7. Visser WE, Friesema EC, Jansen J, Visser TJ. Thyroid hormone transport in and out of cells. *Trends Endocrinol Metab.* 2008; 19:50-56.
8. Visser WE, Jansen J, Friesema EC, Kester MH, Mancilla E, Lundgren J et al. Novel pathogenic mechanism suggested by ex vivo analysis of MCT8 (SLC16A2) mutations. *Hum Mutat.* 2009; 30:29-38.
9. Liao XH, Di Cosmo C, Dumitrescu AM, Hernandez A, Van Sande J, St Germain DL et al. Distinct roles of deiodinases on the phenotype of Mct8 defect: a comparison of eight different mouse genotypes. *Endocrinology.* 2011; 152:1180-1191.
10. Di Cosmo C, Liao XH, Ye H, Ferrara AM, Weiss RE, Refetoff S et al. Mct8 deficient mice have increased energy expenditure and reduced fat mass that is abrogated by normalization of serum T3 levels. *Endocrinology.* 2013; 154(12):4885-95.
11. Herzovich V, Vaiani E, Marino R, Dratler G, Lazzati JM, Tilitzky S et al. Unexpected peripheral markers of thyroid function in a patient with a novel mutation of the MCT8 thyroid hormone transporter gene. *Horm Res.* 2007; 67:1-6.
12. Dumitrescu AM, Refetoff S. The syndromes of reduced sensitivity to thyroid hormone. *Biochim. biophys. acta.* 2013; 1830:3987-4003.
13. Refetoff S, Dumitrescu AM. Syndromes of reduced sensitivity to thyroid hormone: genetic defects in hormone receptors, cell transporters and deiodination. *Best Pract Res Clin Endocrinol Metab.* 2007; 21:277-305.
14. Ramos HE, Morandini M, Carre A, Tron E, Floch C, Mandelbrot L et al. Pregnancy in women heterozygous for MCT8 mutations: risk of maternal hypothyroxinemia and fetal care. *Eur J Endocrinol* 164(2):309-314.
15. Di Cosmo C, Liao XH, Dumitrescu AM, Weiss RE, Refetoff S. A thyroid hormone analog with reduced dependence on the monocarboxylate transporter 8 for tissue transport. *Endocrinology.* 2009; 150:4450-4458.